

## Six Wheeled All Third Coach

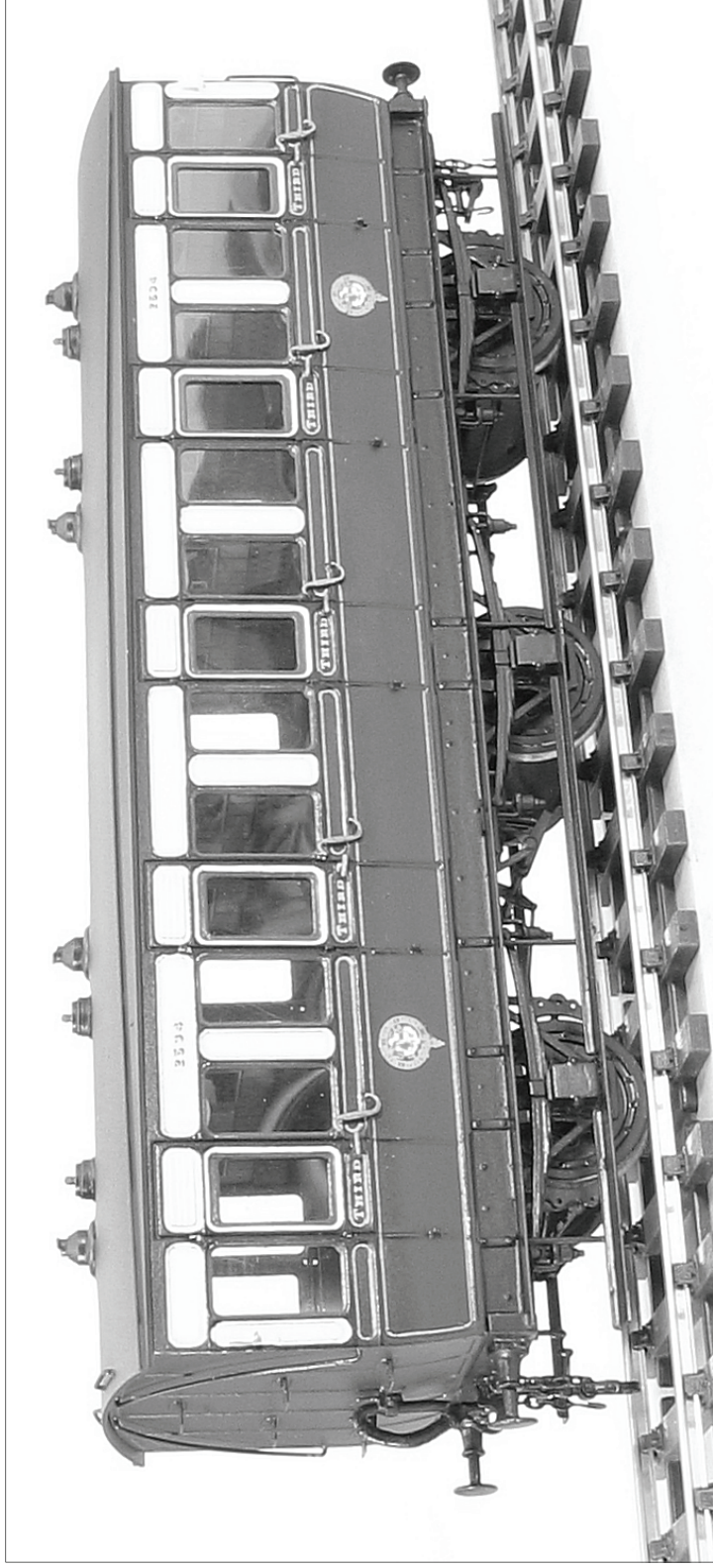

**Prototype.** Most of the pre grouping railway companies built six wheeled coaches to similar designs. Many continued in service on branch lines until the 1950's and others were converted for engineers department use. This kit is based on a S&DJR prototype chosen because it is very similar in appearance to coaches owned by most of the pre grouping companies. Many modellers will be happy to paint it in their chosen railways livery.

**Kit.** This has been designed to provide an economical coach that can be built in a reasonable period of time to a level of detail suitable for running on a layout. A pre-rolled brass roof is provided, as is material to make the floor and compartment partitions. Etched door and grab handles are included. **Wheels, 3'7"**, Mansell Disc (7124) are required to complete, available from Slater's, Telephone 01629 583993.

**Connoisseur Models, 33 Grampian Road, Penfields, Stourbridge, DY8 4UE, Tel 01384 371418**

## GENERAL INSTRUCTIONS

Please read this section carefully, especially if this is your first etched brass kit. Many modellers fight shy of working in this medium, but the basic skills are relatively easy to acquire. Once you've learned how to form and solder brass, you'll find all kinds of modelling possibilities will open up for you.

Assembling an etched kit involves exactly the same skills that a scratchbuilder uses – the only difference is that the cutting out of the parts is already done for you. Some filing and trimming will, however, be necessary from time to time. Where this is the case, I have highlighted it in the instructions.

The main skill to master is soldering and I would recommend a Weller 40 Watt soldering iron. This has a 6mm diameter, removable copper bit. The bit is shaped like a screwdriver and has a bright coating of solder (tinned). This combination of iron and bit shape is ideal for running fillet joints and has a good reserve of heat, that is necessary for soldering small parts on to large components. Note the shape and condition of a new bit, as this won't last long and will need restoring back to this condition.

It is important to keep the bit clean and in good condition as you work. Get a soldering iron stand containing a damp sponge; old oxidized solder is wiped off on this before picking up fresh solder for each joint. If you haven't made a joint for some time you may find that a hard black crust has formed on the bit. Remove this with a brass wire brush (suede brush) and then feed some multicore solder onto each side of the bit to restore a bright surface (referred to as wetting or tinning the bit). After about 8 hours use you will find the bit is in poor condition, with holes and a ragged edge. File the bit back to its original shape using a hand bastard file and then polish the surfaces on emery cloth. Coat the bit with Fluxite Soldering Paste (traditionally used by plumbers) and this will prevent the bare copper oxidizing as the iron heats up. Then feed multicore solder onto the bit to form a generous coating and leave to bubble away for a couple of minutes before wiping excess off to give a bit almost as good as new.

A smaller Antex 25 Watt iron with a 3.2mm screwdriver bit is very useful for small assemblies and detail work such as handrails, but will have insufficient heat reserve for main assembly work. The Antex has a plated iron bit, after a little use with 145° solder a grey oxide appears on the bit that will prevent you from picking up the solder. Touch the bit to some multicore solder and it will flash over the bit, wetting it so that you can continue picking up 145° solder. I have found no problems with mixing the two solders in this way.

I use 145° solder for virtually all assembly work. I prefer it in wire form, available from Branchlines, but it is also produced in stick form by Carrs. I find that its lower working temperature helps to give a quick clean joint. Limiting the build up of heat in components, which may cause distortion. I find that I can hold parts together with my finger ends and make a joint before heat reaches my fingers or other etched parts drop off.

I use 60/40, tin/lead, fluxed multicore electrical solder (melting point about 190°) mainly to keep the iron bits in good condition. As it gives a slightly stronger joint than 145° I sometimes use it for small spot joints on handrail wire, lamp brackets etc, but still use extra liquid flux.

For all brass and nickel silver work I use Carrs green label liquid flux. You will soon get the feel for how much to use but more problems are caused by too little flux than too much.

Before soldering components together, thoroughly clean both surfaces along the join line with a glass fibre burnishing brush. Using your tweezers or a knife blade etc, hold the parts together in the correct position and, with an old paintbrush, run some flux along the area to be joined. Still keeping the parts correctly aligned, pick up a small quantity of solder on the tip of your iron and carry it to the joint (unlike electrical soldering, when you feed solder into the joint). Hold the iron against the joint just long enough for the solder to flash between the parts. Don't let go of the parts until the solder has cooled – this takes from five to ten seconds. To run a fillet of solder along a joint, wait until the solder flashes between the parts and then pull the molten solder along

the joint with the iron tip. Don't load the iron tip with a lot of extra solder, but work the joint in 1" lengths, bringing in small quantities of solder. Brass is a very forgiving material and if you get something out of alignment, use heat from the iron to desolder the joint before starting again. For complicated assemblies, it is a good idea to only tack solder parts together. You can then make adjustments by desoldering until you are happy with the location of parts and then solder solid.

When you need to laminate two or more layers of brass together, align the parts and carefully clamp them together, either in the vice or by holding them with miniature crocodile clips. Run flux around the edges, and then go around with the soldering iron. Clean up thoroughly afterwards.

To fit small parts and overlays on to a larger assembly, such as strapping to a wagon side, when you need to prevent finely detailed areas such as planking becoming clogged up with solder. Tin the back of the small component first, then hold in place on the model and apply flux. Carefully wipe the tip of your iron on a sponge to remove any solder from it (dry iron), and then touch it against the parts to be joined. After a few seconds you'll see molten solder bubbling from the edges. Remove the iron, still holding the parts in place, and allow the joint to cool. An alternative is to use solder paint (I would recommend Carrs 188 solder paste). As the name suggests, this is a flux and solder in one. Simply apply a thin coat of solder paint to the back of the component instead of tinning. Still apply a small amount of liquid flux before you solder the part into place.

Any surplus solder should be removed using a craft knife, I find No 10 curved scalpel blades ideal, then burnish clean with a glass fibre brush. With practice, you'll learn how to use the minimum amount of solder to do the job. Flux is corrosive so, after each soldering session, give your model a good scrub with washing up liquid or Jif. After a day or two, any remaining flux residues will show as a green film, which should be washed away.

To cut parts from the fret, use a sharp Stanley knife on a piece of hardboard or a pointed scalpel blade on a block of softwood. Remove tags and burrs with a fine file.

Three-dimensional parts are formed by folding. On an etched brass kit, the fold lines are normally half-etched on the inside of the fold. You'll be able to fold most parts using smooth-jawed pliers. For longer parts folding bars are desirable.

Other useful tools include a bench vice, a good pair of tweezers, a set of Swiss files (get a full set of cheap ones and then buy quality replacements for the three that you use the most), a pin vice with a selection of drills from 0.5mm to 2.1mm plus a few larger sizes that you use regularly (2.6mm for axle bearings etc), some square-nosed pliers and some very pointed-nosed ones, preferably with smooth jaws. Buy cheap tools first and duplicate the most used ones with quality.

Try to complete all high-temperature soldering before attaching any of the cast whitmetal parts. These can be attached with two-part epoxy resin such as Devcon or Araldite Rapid. Ensure the surfaces to be glued are clean and free of grease.

A better alternative is to solder your white metal castings using Carrs 70 degree low melt solder and Carrs red label white metal flux. The iron should be run at a much lower heat so that you do not melt the castings. I have a domestic light dimmer switch and plug socket fixed to a piece of wood, wired up with a lead and 3 amp mains plug to the input side of the dimmer switch and the output of the dimmer switch into the plug socket (remember to continue the earth). Plug your 40 Watt iron (25 Watt iron won't work) with a clean and freshly tinned bit into this and experiment with adjusting the switch until you find the range of temperature at which the solder melts, but a scrap casting does not. **Note** as the iron is running at a lower voltage it will take longer to heat up, so when you think the adjustment is correct do check a few minutes later on another scrap casting to see that it doesn't melt. Then scribe a mark on the switch knob to indicate this position.

When attaching white metal fittings to brass the surface of the brass must be tinned with 145° solder, to allow the solder to grip. The surface of the casting at the joint should be burnished bright. The casting can then be soldered into place with 70° solder and fillets of solder run into any gaps with no risk of melting the casting.

# SIX WHEELED ALL THIRD COACH

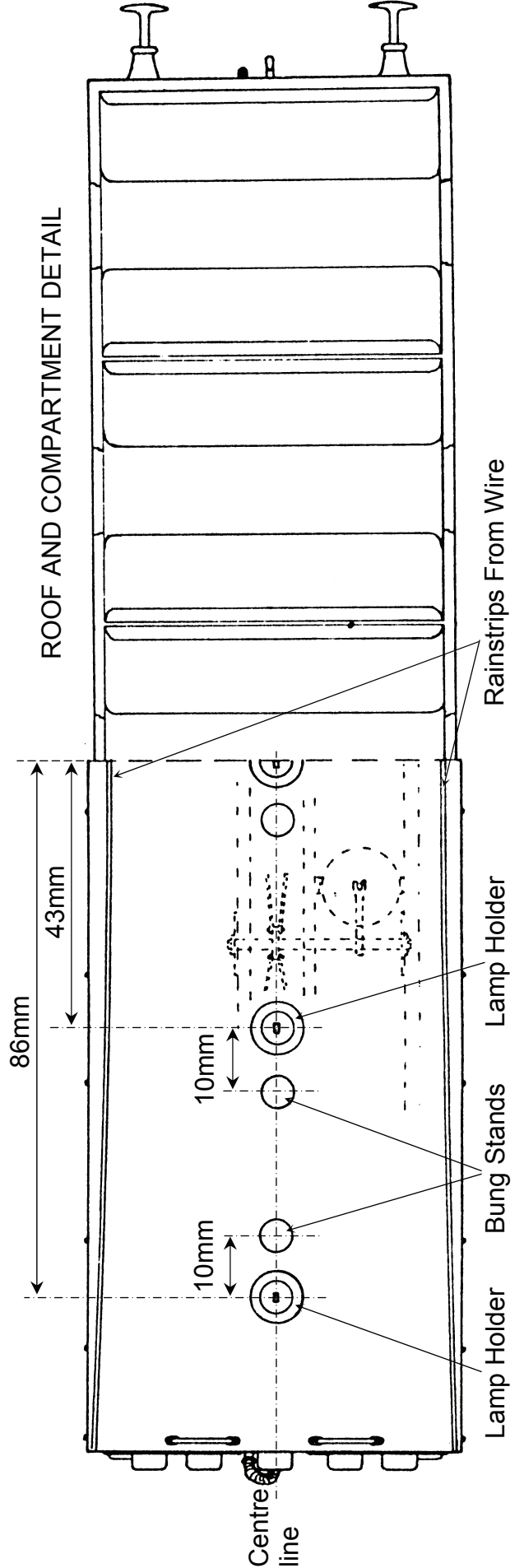
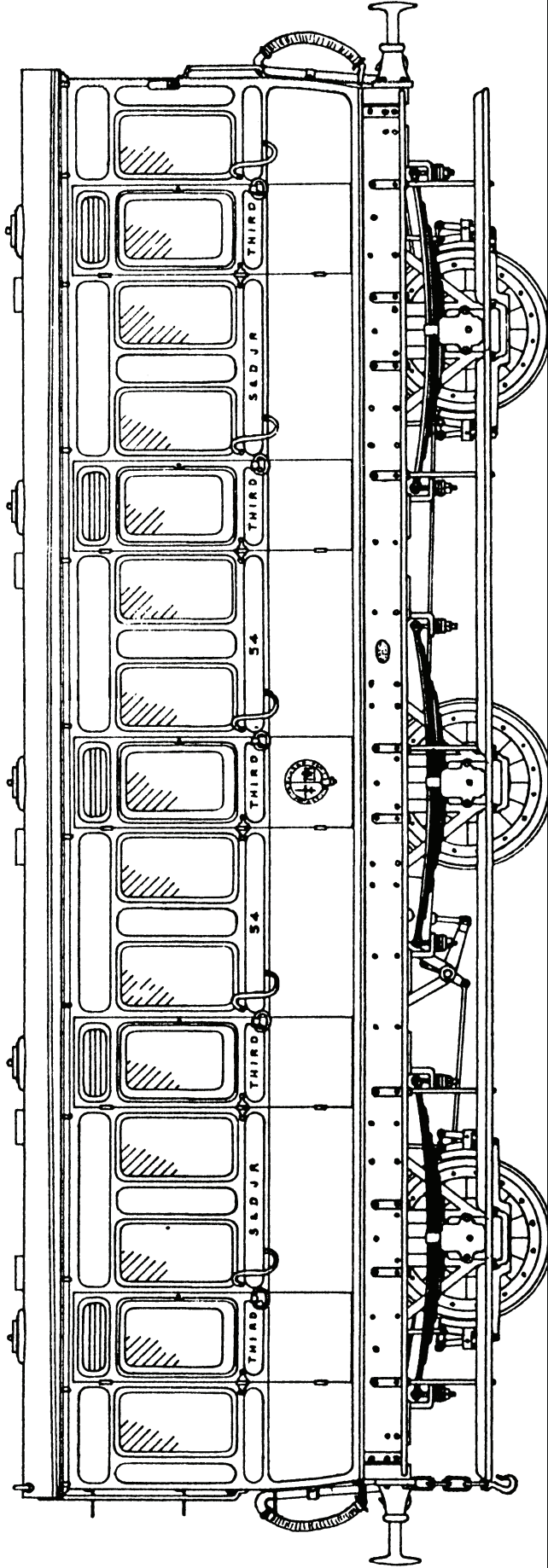

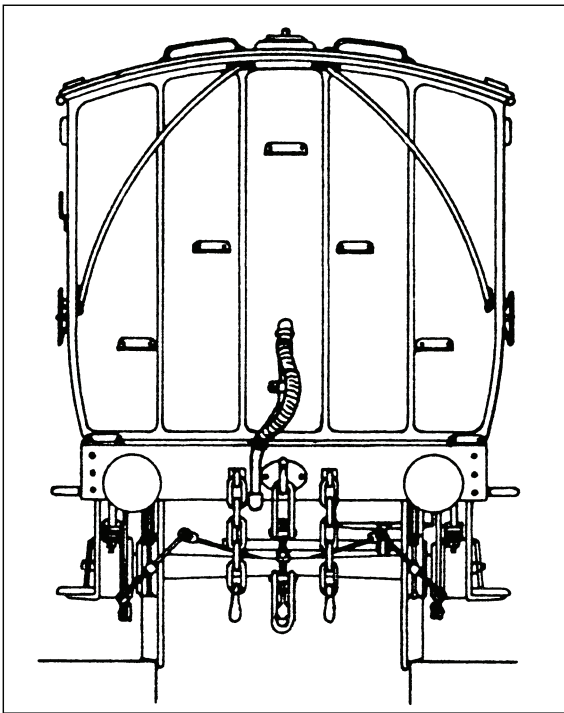

The prototype all third coaches were built by the Somerset & Dorset Joint Railway and then passed into Southern Railway ownership, Sample running number, 54.

S&DJR Coach Livery, Roof - light grey. Bodywork and Solebars - Prussian blue with all panel edges lined in gold. Axle guards, footboards, metalwork buffers etc - black. Post 1912 the panel edges were lined in yellow and solebars and ends were plain black. S&DJR transfers are included on the HMRS Midland Railway coach sheet.

For other railway companies check reference books but most six wheelers were finished in simple liveries in later years. For example the LNER used plain coaching stock brown bodywork with plain yellow lettering. Black solebars and grey roof. A range of transfers for different railways are available from the Historical Model Railway Society, 8 Gilpin Green, Harpenden, Herts, AL5 5NR.

## Six Wheeled All Third Coach Etched Parts Identification Numbers

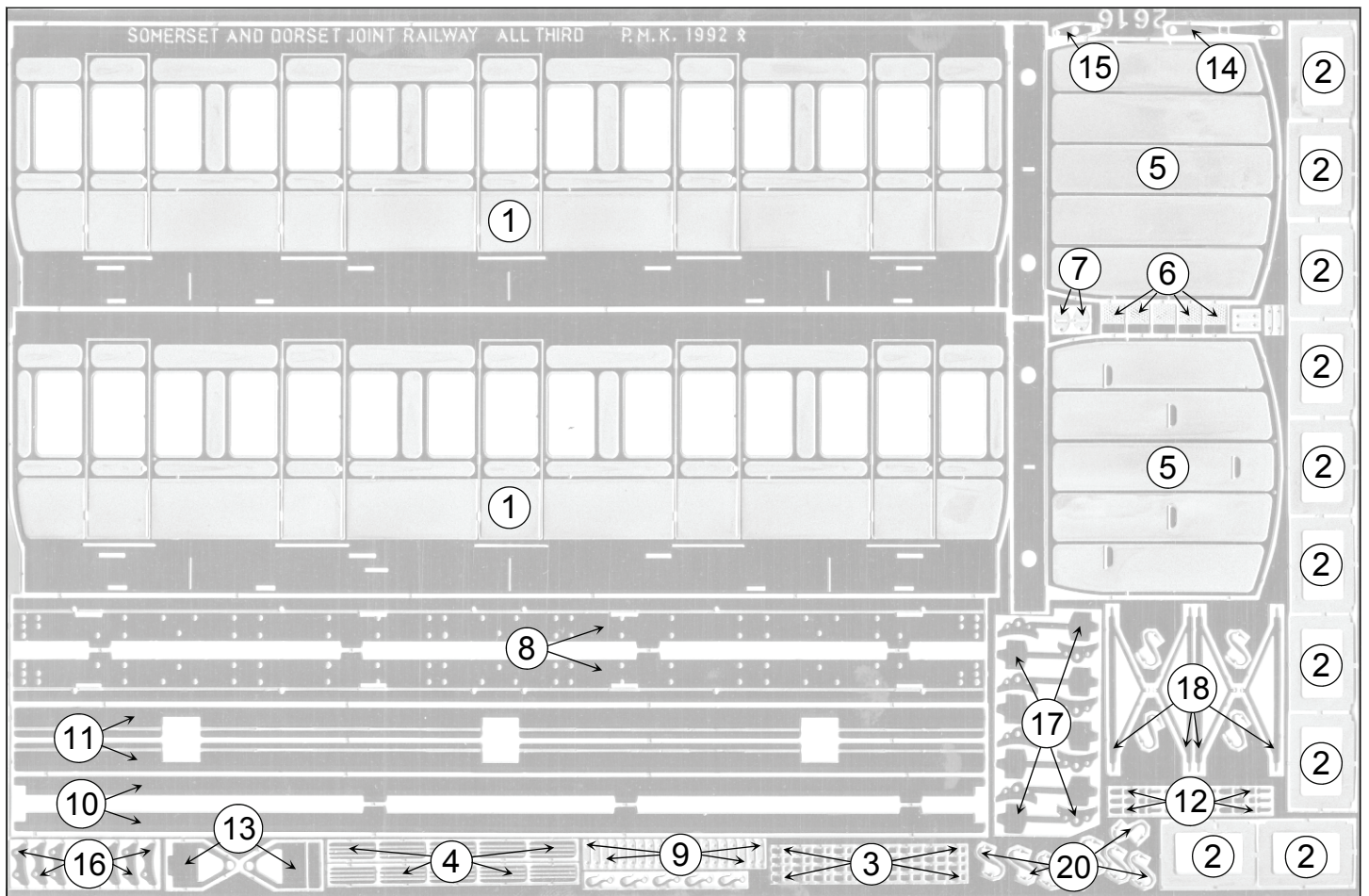
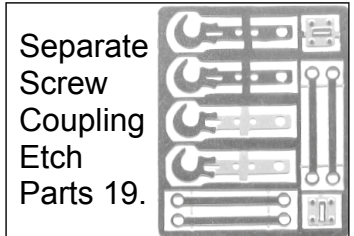

# SIX WHEELED COACH MAIN BODY ASSEMBLY

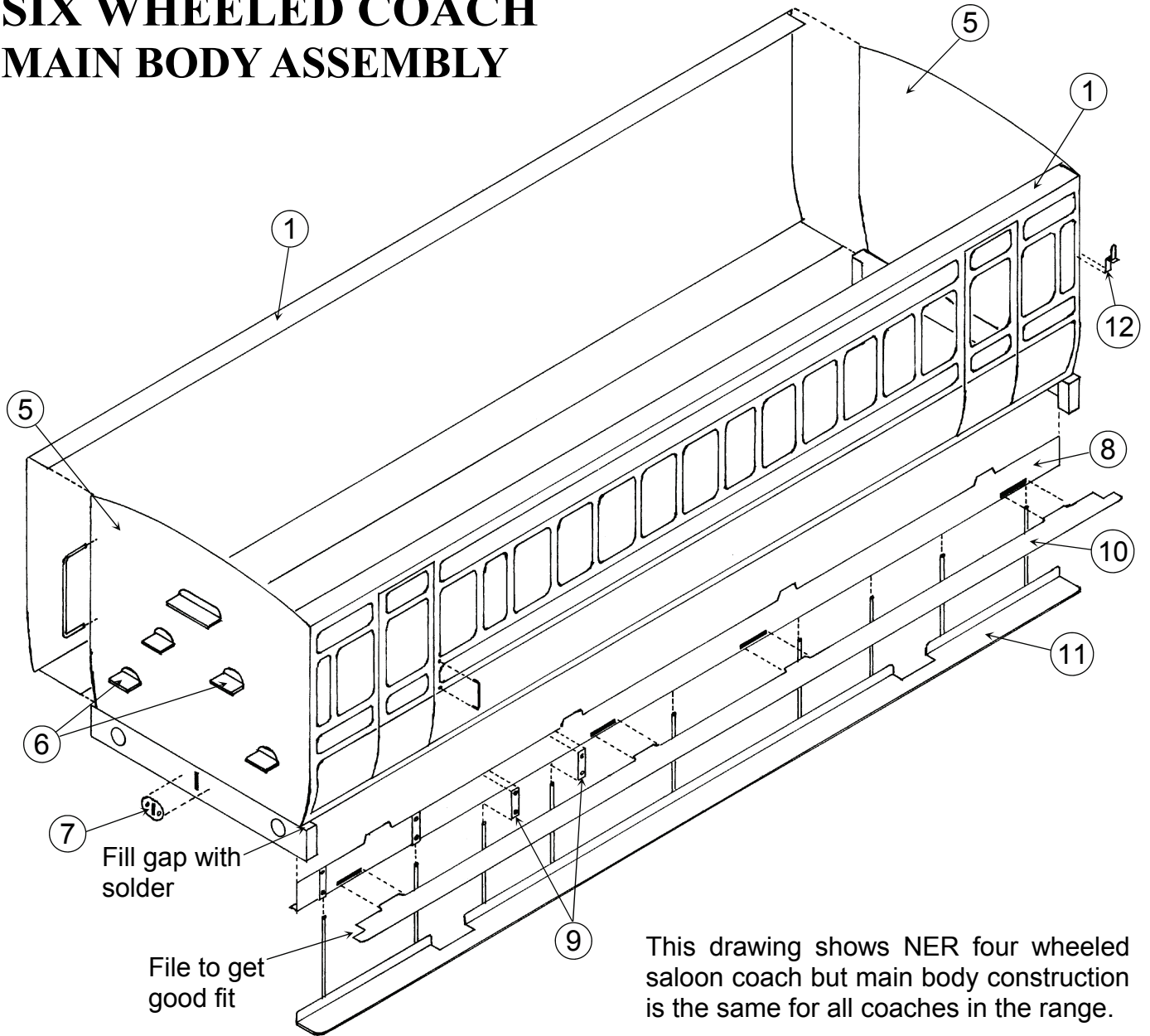

This drawing shows NER four wheeled saloon coach but main body construction is the same for all coaches in the range.

## DROPLIGHTS AND DOOR HINGES

Fit before main assembly

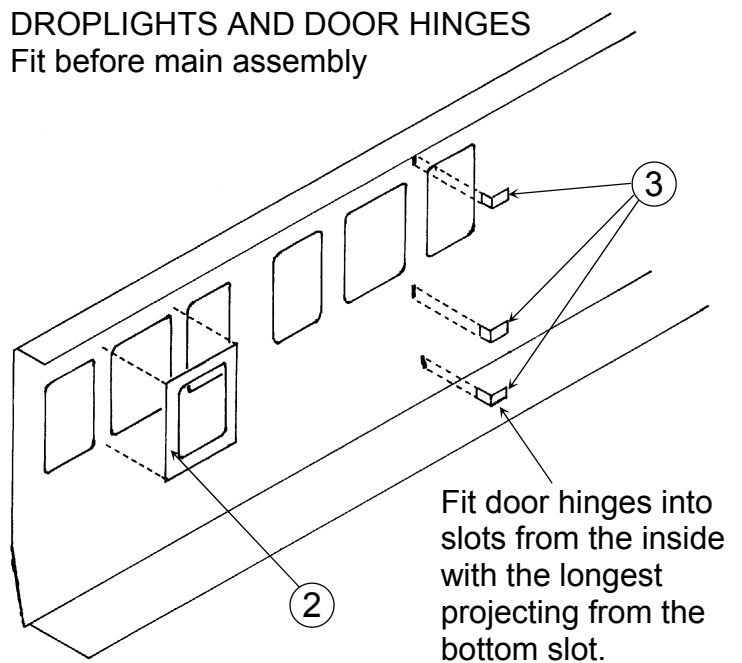
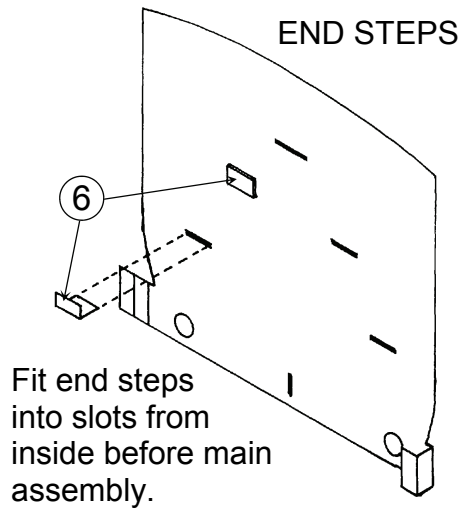

## SIX WHEELED ALL THIRD COACH ASSEMBLY INSTRUCTIONS

1. I prefer to add components to the sides and ends before assembling them into the body of the coach. First take the sides (parts 1) and fold the top edge through 90 degrees (a set of simple bending bars are recommended for all the long folds of the coach and this first fold is made by clamping the side and folding the top edge). Then form the curved tumblehome at the bottom of the coach side.

Forming the tumblehome is an easy operation but is something of a mental hurdle for many modellers and puts them off starting a coach kit while they dream up complicated ways of doing it involving jigs and formers. Its one of those jobs that once you have done it you can not believe how easy it was and wonder why it frightened you for years.

I form the tumblehome using only a foot long off cut of 3/4" copper water pipe (most forming jobs from cab roofs to loco smoke boxes are started with this pipe off cut). I work the coach side over the pipe gently forming the tumblehome curve with my fingers and thumbs. I find it easier to work with the pipe held in my hands rather than down on the bench and in this way I find that I can roll the pipe underneath the side as I form the curve using pressure from my thumbs on the front surface of the side. I form about a 2" length of the side at a time working from one end to the other. I find it requires three stages to form the tumblehome. The first to put a rough curve along the entire length of the side, the second to form the correct radius along the entire length. This radius wants to be slightly tighter than the curve on the coach end so use a end as a guide to form this radius at the two ends of the side and then match up the centre section by eye. The third stage is to remove any slight irregularities and kinks by gently working with just fingers and thumbs as you eye down the length of the side. Then clamp the bottom edge in the bending bars and using a steel rule to help transfer the pressure evenly along the tumblehome, gently fold the side through 90 degrees (the steel rule will help to prevent flattening out of the tumblehome curve that you have just put so much effort into forming). When you make this bottom fold it will also help to remove any last slight irregularities in the tumblehome curve. You will note that the bend line for this fold is not a continues half etched line but has short full etch sections in it to reduce the amount of pressure required to fold the side. Once you have assembled the sides and ends and are happy with them you may wish to run a fillet of solder along the inside of the fold to strengthen it. If you use plenty of flux some solder should flow through the full etch sections filling any slight gaps that may be visible and then you can dress the bottom of the side with a flat file to give a crisp outside edge. Don't reinforce this fold before assembly of side and ends or you wont be able to tweak any slight adjustments into the bottom strip to make it completely flat.

You should try to get the tumblehome curve as even as possible but if you go to a preserved railway and look along the tumblehome of a wooden panelled coach you will be surprised at how uneven they are.

2. Fit the droplights (parts 2) behind the door window openings. I place a droplight onto a piece of 1"X1" wood and then place the coach side on top so that I can centre the window opening over it and then fix it with a single tack of solder. I then turn the side over and solder the droplight firmly to the rear of the side.

Fold up the door hinges (parts 3) and fit into the slots from the rear with the longest projecting ones at the bottom. I hold them in place with a knife point and using plenty of flux spot solder them. Hopefully some solder will flow through and fill any gaps in the slot around the hinge but if you only use a small amount of solder it shouldn't run up the door lines requiring a lot of scraping with a knife blade to clear it.

Fit the door ventilators (parts 4) centrally into the top panels. I tin the backs first and then holding them into place with a knife point and using plenty of flux sweat them into place using only a small amount of solder on the iron bit therefore requiring very little cleaning up.

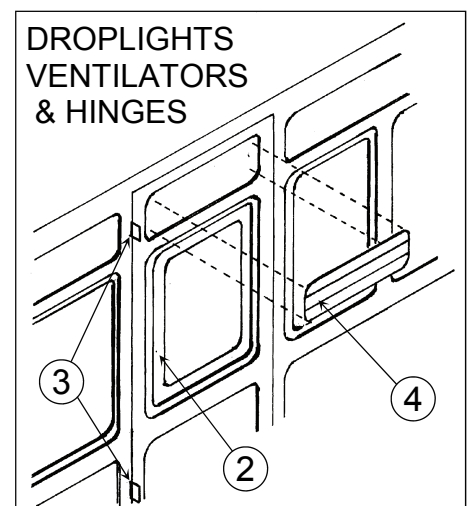

3. Take the coach ends (parts 5) emboss the bolt heads for the step plates and then fold the bottom to form a U section to represent the ends of the buffer beam. Fold up the steps (parts 6) and fit into the slots from the inside. Use plenty of flux so that the solder flows through the slots to fill any gaps. Fit the coupling plates (parts 7) located over the coupling hook slot in the buffer beam. I tinned the back of the plate and sweated it into place to reduce the risk of solder filling the slot.

Now assemble sides and ends together. The top and bottom strips of the sides and the fold around ends of the buffer beams will help with positioning. I place the plain coach end onto a flat surface and locate a side onto it tack soldering at the bottom strip joint. I repeat for the second side and then fit the stepped end at the other end to make up the box of the body. Check that you are happy with the position of the parts and that it looks as if the body will not be twisted. If required adjust by resoldering the joints. Place the plain end down again and run fillets of solder up the inside of the joints. Again work 1/3 at a time on alternative sides (watch out for the ends bowing inwards with the heat) and then repeat for the stepped end. Then dress the outside of the joints to give crisp square corners.

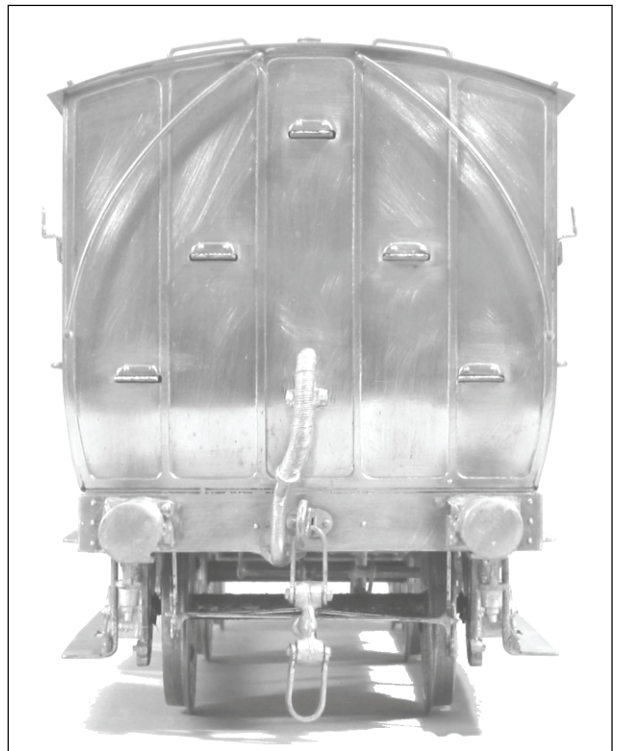

4. Take the solebars (parts 8) and emboss the bolt heads. These bolt heads are designed to be embossed using a scribe with the point rounded off slightly on an oilstone. Place the part, face down, onto a block of softwood and then press the scribe point firmly down into the half etched hole, this may distort the part slightly, so gently correct this by bending back with finger and thumb pressure. If you have a rivet forming tool, particularly of the drop weight type, you should find this ideal but as I like to make the half etched holes fairly generous to allow for scribe embossing go gently until you get the feel for the amount of drop required.

Then fold the bottom of the solebar through 90 degrees. Solder the foot board brackets (parts 9) to the face of the solebars (note the etched marks to help with location). These brackets fit level with the top edge of the solebar but slightly short of the bottom edge (level with the top of the four slots) to allow for fitting the footboard. Fit solebars locating in slots on underside of body, a little filing at the ends may be necessary to get a good fit, and also solder well at the buffer beam joints to hide any gaps.

Fit the top footboards (parts 10) locating into the four slots. It may be necessary to dress the ends to get a snug fit around the buffer beam ends.

5. Take the bottom footboards (parts 11) and fold the back edge through 90 degrees. Then place along the edge of two off cuts of 2"X1" wood and fix in place with drawing pins. Place the two pieces of wood opposite each other, parallel and about 2" apart. Solder across lengths of 0.9mm brass wire located into the etched grooves on the footboards. As the footboards can be a little vulnerable to damage I would suggest using 60/40 solder for these joints. Then snip the wires down the centre to separate into two footboards with hangers.

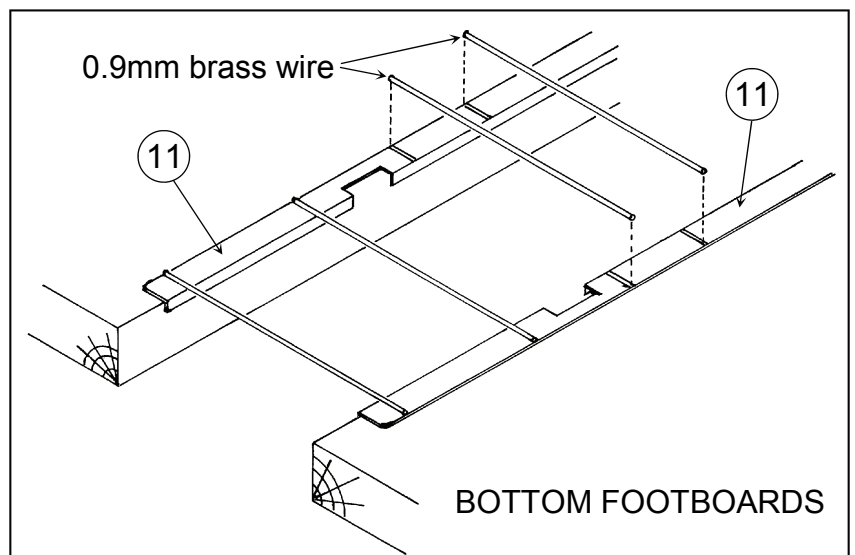



Now clamping the footboard at the wire joints in the jaws of a vice and fold the wires through 90 degrees. Try to make this fold as tight as possible. Then cut down the wires to 19mm from the top surface of the footboard. If you cut a strip of card 19mm wide this will act as a template to get the wires all the same length.

Run a 1mm drill through the holes in the solebars to clear them and then fit the footboards. The footboard hanger wires should pass through the holes and touch the bottom strip of the coach side. This should set the position of the footboard about level with the bottom of the cast axlebox. Solder the wires with a good solder joint (again I use 60/40 solder for strength) into the holes. The lengths of wire that project through the solebar will interfere with the fitting of the cast axleguards later in the construction so snip them off once you are happy with the position of the footboards

6. I now prefer to fit the lamp brackets (parts 12) and handrails. The central fold on the brackets is a reverse fold and folds back upon itself. I reinforce the folds by holding the bracket in a pair of long nosed pliers and flood the folds with flux. I then touch the tip of the soldering iron loaded with a small spot of 60/40 solder to the side of the bracket and the flux draws the solder into the folds. I then tin the backs of the bracket with 145 degree solder, hold them in position with a knife point and sweat them into place. Refer to drawings and illustrations for position but different railway companies had different practices for the position and number of brackets so do a little prototype research.

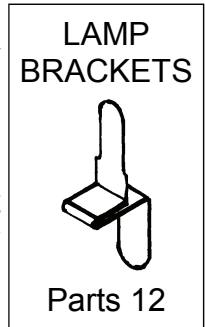

Handrails are made from 0.7mm brass wire. Clear the holes if necessary with a 0.75mm drill. You may find a piece of thin card useful to help space the wire away from the body as you solder it. Slightly annealing the wire with a cigarette lighter will help in forming the curved end handrails.

7. Fit the cast axle guards and wheel sets. My casting technology is not very sophisticated and you will probably find that an amount of flash will require removing from between the W irons and around the spring ends. I find that a number 10A pointed scalpel blade is best for this and you will get the best results from using a new blade or two. Take four of the axle guards and drill out the hole to 2.6mm diameter to take the brass axle bearing. Try to ensure that these holes are square to the back of the axle guard. If you use the drill in a hand held pin vice (chuck) you can check for squareness and make adjustments by applying a gentle sideways pressure as you drill out the hole. The Holes should be slightly oversize with the bearings a lose fit.

I find that it is best to fit the two outer wheel sets first so slip a wheel set with the axle guards on between the solebars as a dry run to check how they will fit. The axle guards should fit hard against the lip of the solebar and should be square when viewed from the end. Check that they are not being forced outwards by the axle (bottom of axle guard not sitting snug against the solebar or bearing holes not deep enough) or sloping inwards (to much side play on the wheels, about 1/2 mm side play is the maximum desirable). A small notch will have to be filed in the casting to fit around a footboard support and they will also prevent the buffers from fully depressing so you may wish to file a cut out at one end to clear the buffer retaining collar

Once you are happy with the dry run and the fit of the axle guards then fit the bearings with a small blob of Evostick, slip wheel sets with axle guards on between the solebars and fix to the solebars with a single tack of low melt solder. Check that the axles are

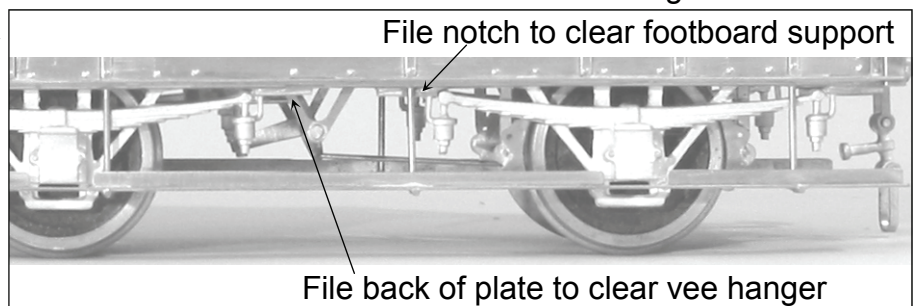

parallel and the axle boxes are centred in the footboard cut outs (there are etched marks on the underside of the coach body that are also useful to eye up on when positioning the axle guards). Then place the coach on a flat surface to check that it sits down flat and doesn't rock on its wheels. Check that the coach body is not twisted and then adjust two axle guards at opposite corners by resoldering slightly downwards, when happy solder solid. As the Evostick takes a little time to set you can make these adjustments to the axle guards and then leave the coach on a flat surface for the glue to set.

Once the Evostick has set in the outer axle guards you can fit the centre ones. Drill out the bearing holes 2.7mm diameter (slightly oversize) and file the spring end plate slightly to clear the vee hanger. To achieve maximum side play file down the pin point ends of the axle until the bearing nearly touches the wheel centre. Fit wheels and axle guards with the bearings loose (no glue) so that there is a little up and down movement in the wheel sets.

With this maximum side play on the centre wheels and slight up and down movement achieved by the loose bearings. I find that I can propel this coach (admittedly at slow speed) through the 4'6" radius points on my layout with complete reliability and that the centre wheels quiet happily rattle along over the humps, hollows and dodgy rail joints of my track work. But if you have tighter curves or really bad track work you may wish to look at some of the inside bearing compensation units that are produced by a number of the specialist component manufacturers.

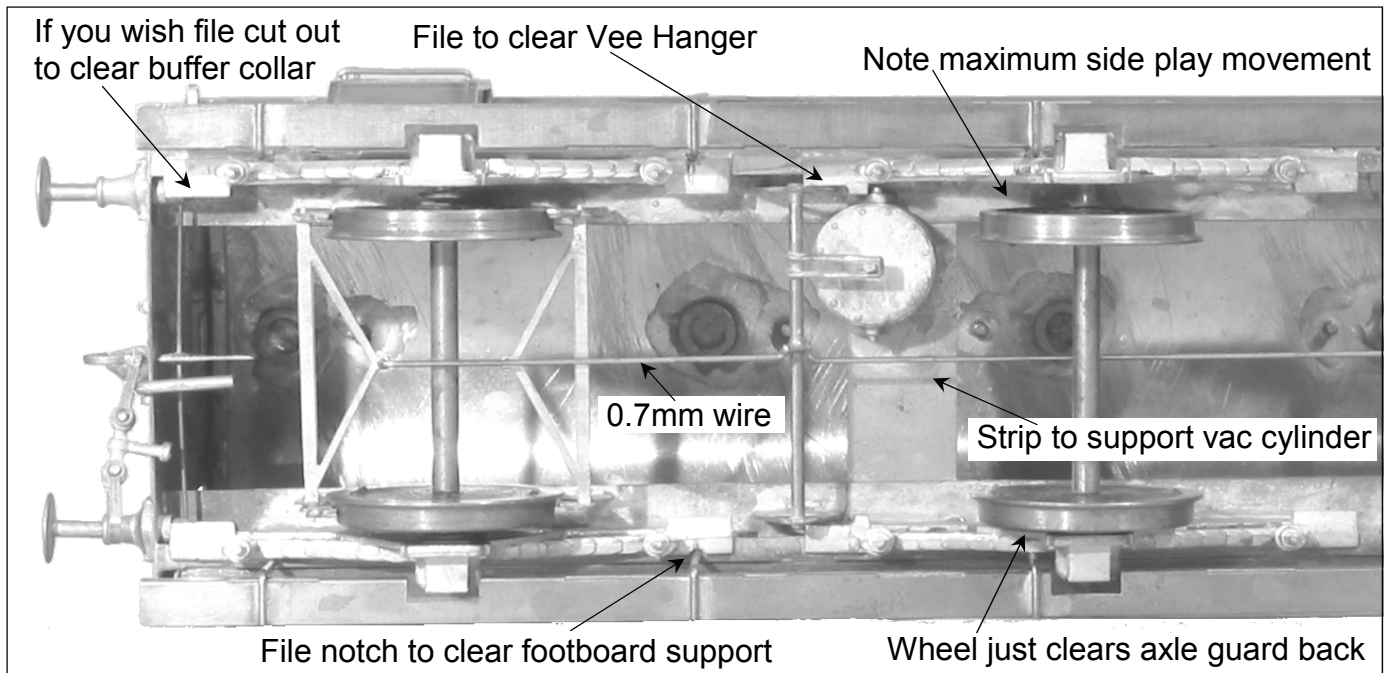

The above illustration shows the underside of the brake 3rd coach but the all 3rd is the same with the exception that the second vee hanger is fitted to a wider rectangular strip 2/3 of the way across the coach and the brass rod is correspondingly shorter.

8. Fit one vee hanger (parts 13) into the slot in the underside of the coach body and then solder the rectangular strip of brass across the inside of the coach. Fit second vee hanger with folding base 2/3 way across the rectangular plate. Fold up and tin the end of the vacuum cylinder linkage (part 14). Cut a length of brass rod 2mm longer than the distance between the vee hangers and dress the ends square. Pass the rod through one vee hanger, thread part 14 and the brake pull rod crank (part 15) onto the rod and then solder the rod into the vee hangers so that it projects through by 1mm. Leave parts 14 and 15 to swing free. Trim off the bases of the two cast supports and fit to the vacuum cylinder so that it is set at a slight angle. Solder cylinder into place on the brass strip using the linkage (part 14) to help with positioning. Then solder linkage to brass rod and vacuum cylinder. Solder pull rod crank to brass rod on coach centreline set about 10 degrees from vertical.

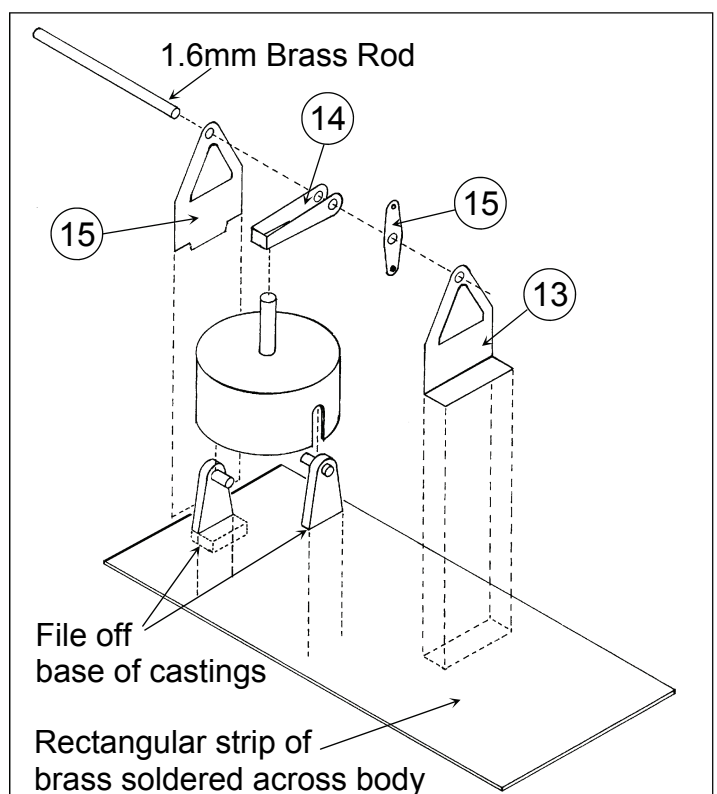

9. Solder the brake blocks (parts 16) to the brake hangers (parts 17) remembering to make up L/H and R/H sets. Fix brake hangers into slots on underside of coach body so that they are just clear of the wheel tread. I find that a miniature electrical crocodile clip is useful to hold the brake hanger for this operation. Spring the brake yokes (parts 18) between the brake hangers and solder so that the inside one runs slightly up from the horizontal and the outside one slightly down from the horizontal. Link the outside yokes back to the pull rod crank at the vee hangers with 0.7mm brass wire. On the prototype coach there was quite a complicated arrangement of rocking links around the yokes that I don't bother to model.

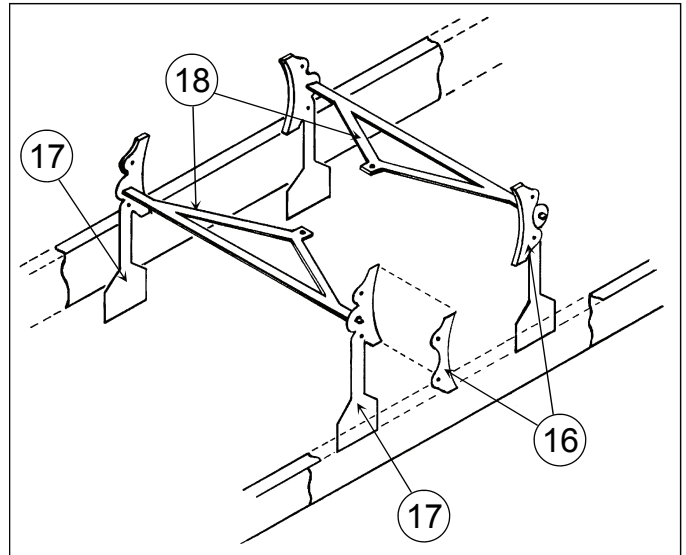

10. Drill out the buffer bodies with a 2.1mm drill to take the cast buffer head/shank. Hold the drill in a hand pin vice (chuck) and grip the buffer body between finger and thumb. Drill through the body from each end so that the hole breaks through in the middle. Use a little spot of spit on the end of the drill and this will help prevent the drill wandering in the white metal and breaking through the side of the buffer. Then fit shank through buffer body,

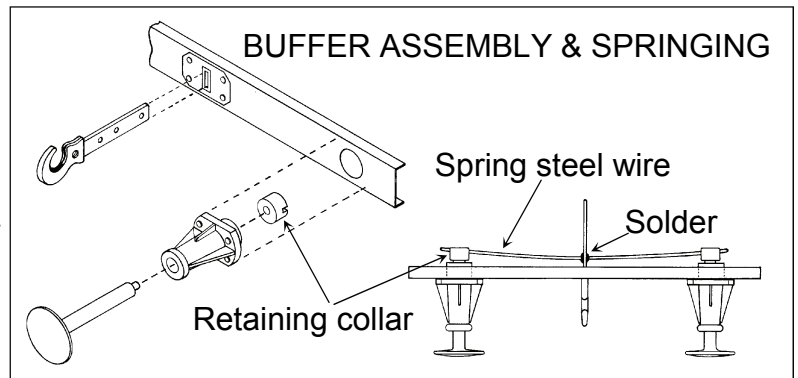

snip off some of the narrow end of the shank to leave just over 1mm from the step, and solder a retaining collar onto the shank. Open up holes in buffer beam slightly and fit buffers.

11. Cosmetic screw coupling (parts 19). Solder both halves of each hook together (you may wish to dress the hook with a flat file to achieve a more prototypical profile) and if necessary round the slot so that the link will swing freely and then using round-nosed pliers form the four links into U shapes. Dress the tops of two links with a file so that they will pivot freely in the slot in the hooks. Thread one of these links through the hook and spring the ends over the pegs on the cast centre. Then fit the bottom link.



Pass the coupling hook through the slot in the buffer beam and retain it with a length of spring wire. Polish the centre of this wire with emery cloth first so that you can solder it to the coupling hook shank once you are happy that the buffers spring freely.

Fit the cast vacuum brake pipes on the centreline of the coach ends. Soldering at fixing bracket and buffer beam.

Fold up ends of grab handles (parts 20) and reinforce folds with 60/40 solder. Solder into the two holes (may require drilling out) next to the doors. A sliver of thin card between may be helpful. Fit etched T door handles into doors.

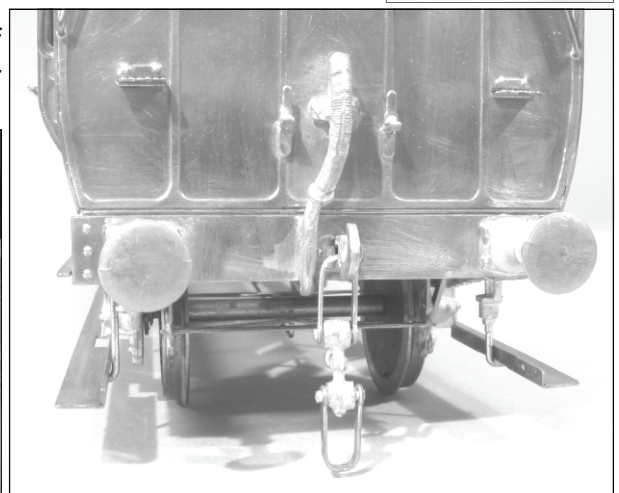
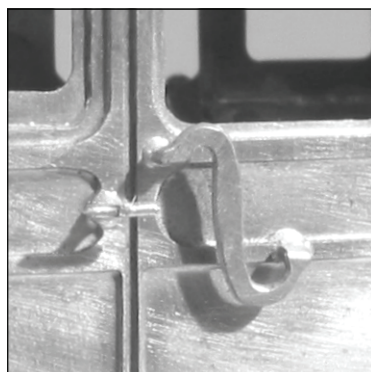

12. I have passed the roof through rolling bars but it will probably require a little hand forming to get the final shape. Work it with fingers and thumbs over a off cut of water pipe in a similar way to the side tumblehome. Once happy with the shape mark out with reference to the main drawing and drill holes for the lamp holders and bung stands. The lamp holder holes are a large diameter and it is impractical to use a drill of this diameter as it will tend to tear the thin brass of the roof. I would suggest drilling a 1mm pilot hole to mark the centre and then open this up with drills until you reach a diameter at which it starts to snatch at the brass. Then switch to a tapered reamer and continue opening the hole up to the correct diameter for the lamp holder.

Mark centre and end points of the rainstrips on the roof and fit 0.7mm wire to represent this. I would recommend spot soldering a straight length of wire that is parallel to the roof edge at the centre point first and then moving each end of the wire to the end point. Then holding into place with a knife point spot solder the ends. The wire should have naturally formed an even curve. Then using plenty of flux and holding with the knife point solder the entire length of wire to the roof. Start at the end points and working short sections from alternative ends with the iron bit on the inside of the curve work to the centre point. In this way you will reduce the tendency for the wire to expand with the heat and by working on the inside of the curve any expansion should still maintain an even curve.

Then fit lamp castings to roof. For daytime running fit bung into lamp holder and for night time fit lamp into holder and bung into stand.

There are two grab handles above the end steps at the end of the roof. Drill 0.75mm holes for these and make grab handles from 0.7mm brass wire. If you don't want to glue the roof into place using Evostick after painting (this glue joint can be split with a knife blade if you ever need to get inside the coach). You may wish to fit some strips made from scrap etch to the underside of the roof so that it fits like an English snuff box lid.

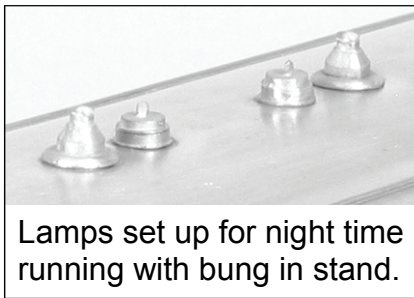

Lamps set up for night time running with bung in stand.

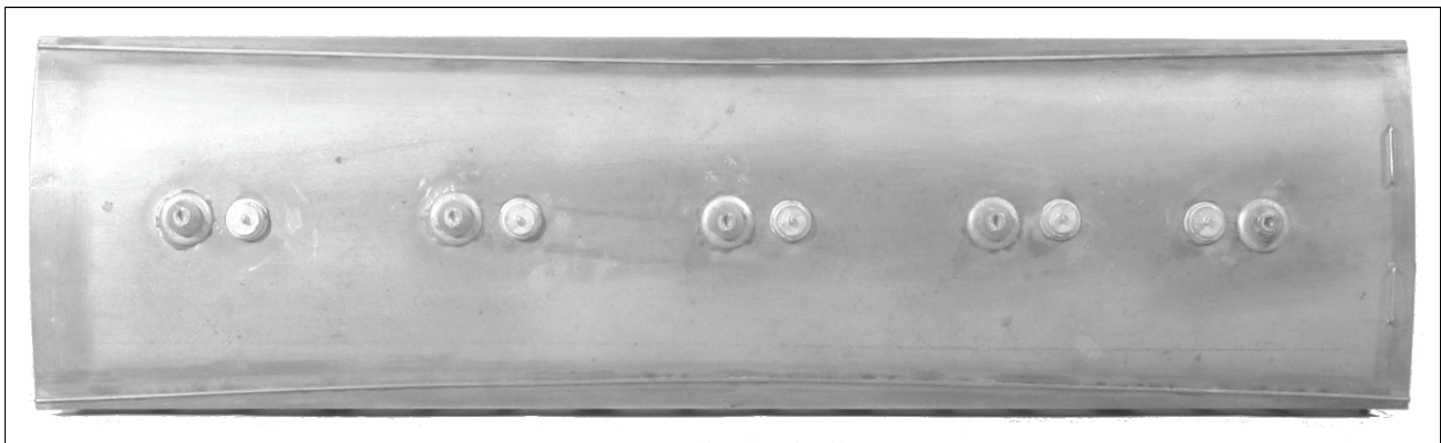

Also included on the etch are some small hooks that can be used in conjunction with fine chain to represent the safety chains that some railways fitted either side of the coupling hook. There are half etched marks on the inside of the buffer beams to mark their position.

13. Painting is a vast subject that cannot be covered fully here. The important thing with a metal model is to get a good base coat of primer. Hopefully you have been cleaning up and washing the model at the end of each modelling session, but it will still need thoroughly cleaning before painting. I give my models a good scrub with a stiff-bristled paint brush in a sink full of hot water, as hot as your hands can bear, and cheap washing up liquid (the expensive stuff that's kind to your hands has an oil in it that will stop the paint keying to the metal). If you know somebody who works in catering and can scrounge you some industrial-strength liquid, this is better still. Then rinse the model a couple of times in clean warm water and place in a dust-free box to dry. I use car aerosol primer and Halfords grey primer is one of the best. For the best results you want to spray at room temperature (25°C) on a dry day, avoid cold, damp or humid days. I find it helps to warm the model to about 30°C (put it in the airing cupboard overnight) and I warm up the paint tin by putting it onto a radiator (about 40°C, but use your common sense as I don't want anybody blowing themselves up). I find it best to prime the model in two light coats, about 15 minutes apart and then leave for 48 hours to harden off (in the airing cupboard in a dust-free box).

I brush-paint my models with Humbrol enamel (you may wish to look at car aerosol paint for the main body colour). For years I just stirred it up and painted straight from the tin but I was never completely happy with the results. Recently two things have transformed my painting. The first was a copy of Martyn Welch's book, *The Art of Weathering*, Wild Swan Publications, ISBN 1 874103 11 9. Martyn's basic techniques are very useful and almost foolproof. Martyn's method of mixing a little coarse talcum powder into the paint to give a slightly textured roof is particularly effective. The second thing is to mix the paint in the tin and then transfer it to a palette (a sheet of clean plasticard) with blobs of lighter and darker shades of paint surrounding the main colour. Then work the paint with the brush on the palette, slightly varying the tones of the paint. This seems to totally change the texture of the paint and the way it goes on and covers on the model.

Fit a floor made from the card that the etch was packed on. This is a good quality mount board card and is very stable. I prefer to fit a card floor rather than brass or plastic as it tends to deaden any tinny rattling noise as the coach is running giving a more prototypical rumble. Glaze the windows using clear plastic sheet (you may wish to try model aircraft shops for this) glued into place using Micro Sol Kristal Klear a PVA type adhesive beloved of aircraft modellers which seems to stick glazing to any other material and as its name implies dries absolutely clear.

Then fit compartment partitions again made from the card. I prefer to paint the entire interior matt black as I find that a fully detailed interior is hardly visible when running on a layout.

Glue the roof into place with Evostick, used as a contact adhesive following the manufacturers instructions.

**Prototype Reference**, This coach was developed from an article in the July 1975 issue of *Model Railway Constructor*.

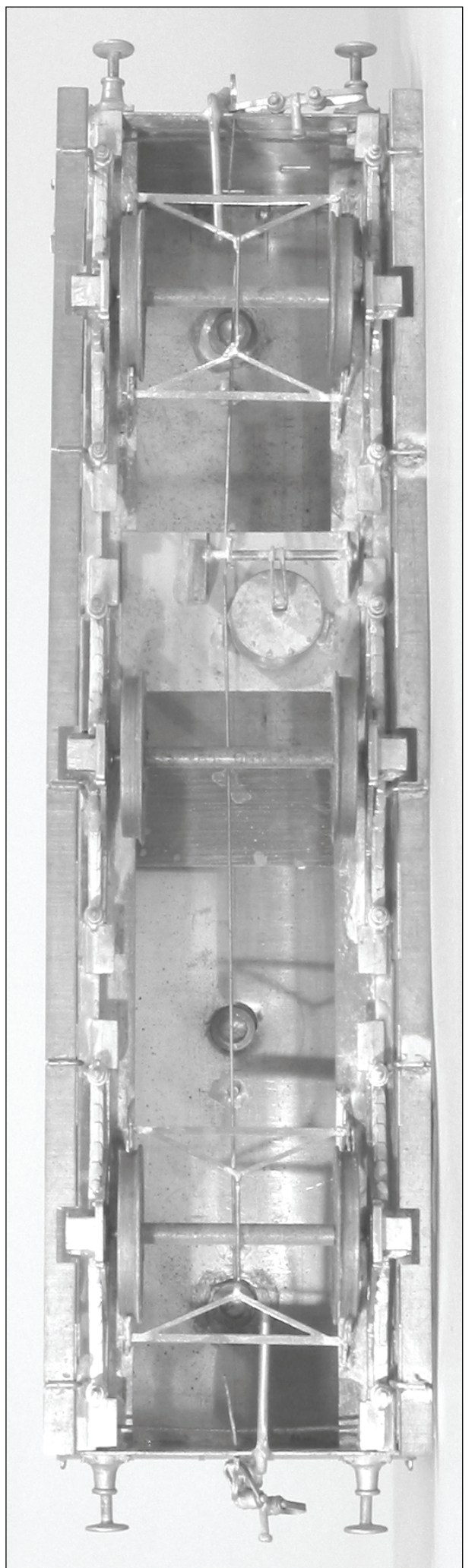
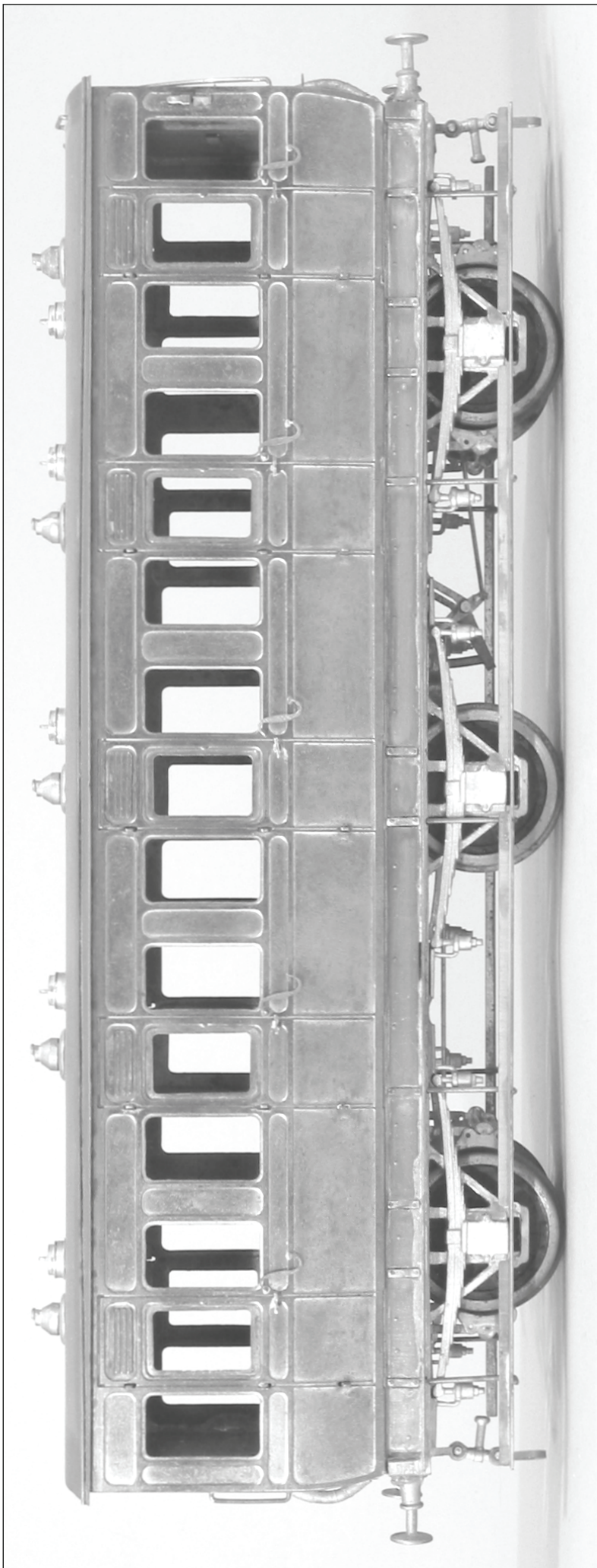

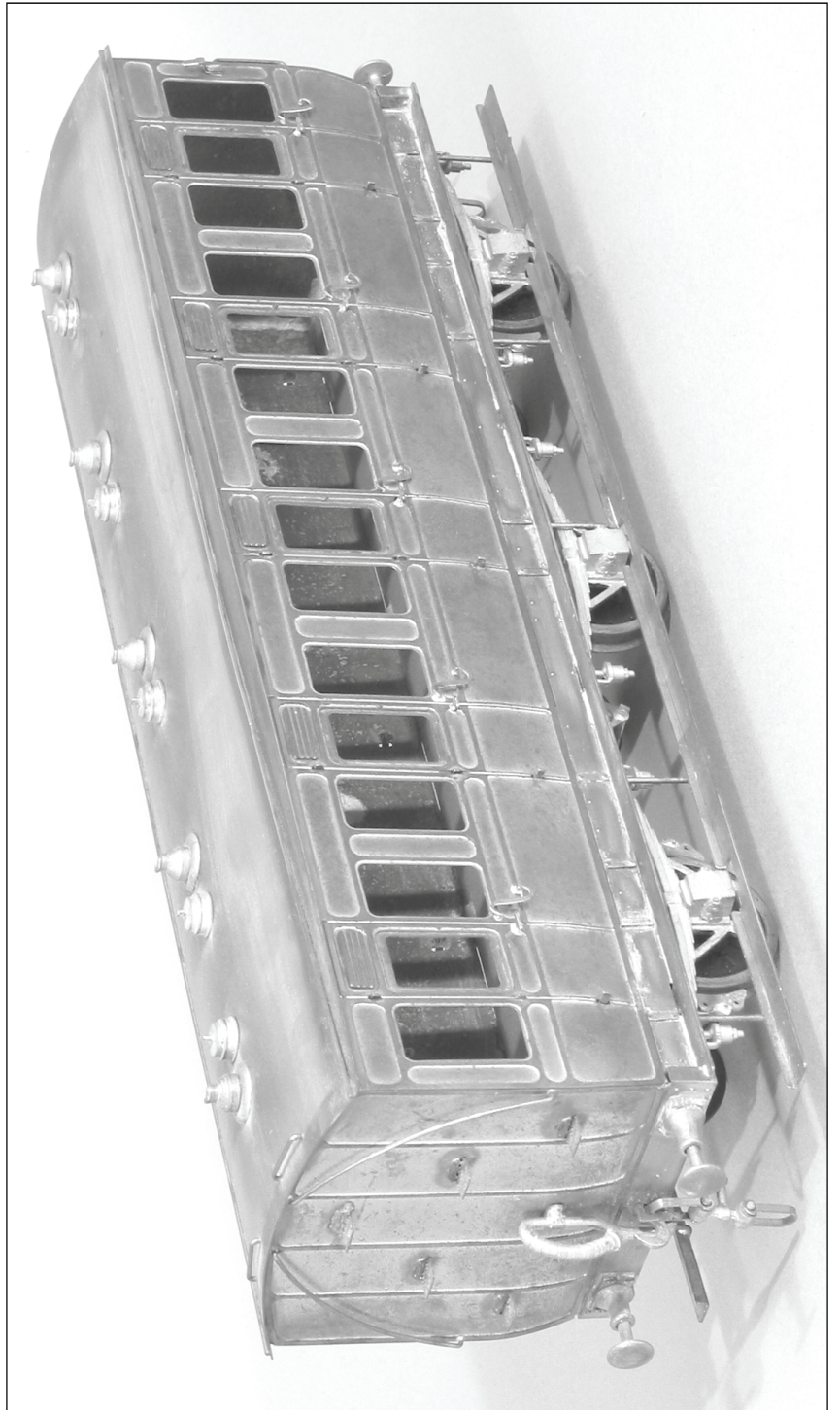
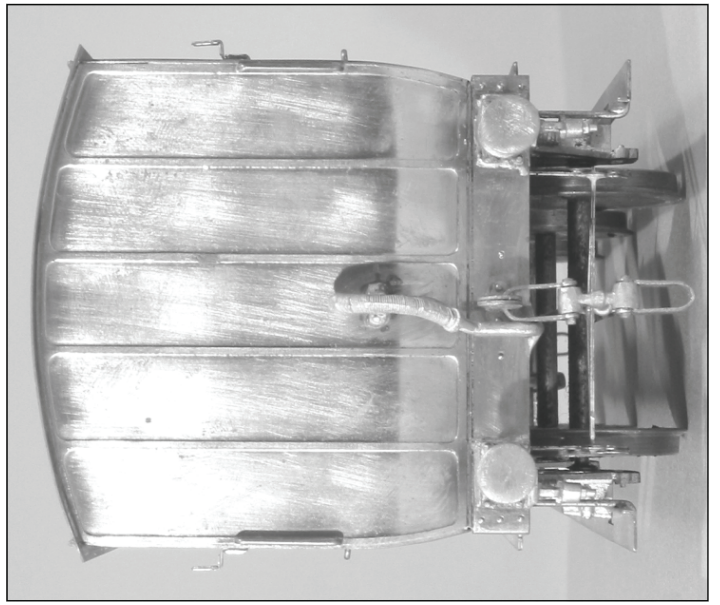
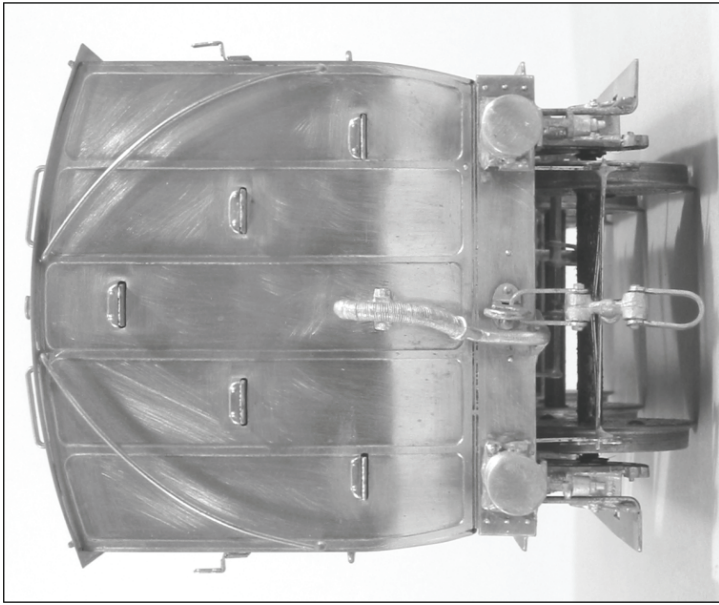

## Tapered reamer & Fibreglass Scratch Brush

The use of these tools is mentioned in the instructions. These and most other general modelling tools can be obtained from Squires Model and Craft Tools, 100 London Rd, Bognor Regis, West Sussex, PO21 1DD, Tel 01243 842424. They do a free catalogue and a very good mail order service.



The scratch brush is like a propelling pencil holder into which a fibreglass refill is fitted and which will give a vigorous abrasive action. I find this tool indispensable for cleaning up and removing solder. One very useful tip is to soak the refills in dilute PVA glue (Evostick resin W wood glue let down 50/50 with water and a spot of washing up liquid) and then drill holes in a block of wood and stick the ends of the refills in the holes while they harden off. This will make the refills much more abrasive and longer lasting, and also stops the fibres breaking off and ending up in your fingers. You will need to give the refill a good rub to get it started but if you use green label flux you will soon have plenty of rusty tools that need cleaning.

I used a tapered reamer to open up the holes in the roof for the lamp holders. I find this tool invaluable for building etched kits

## Folding Bars

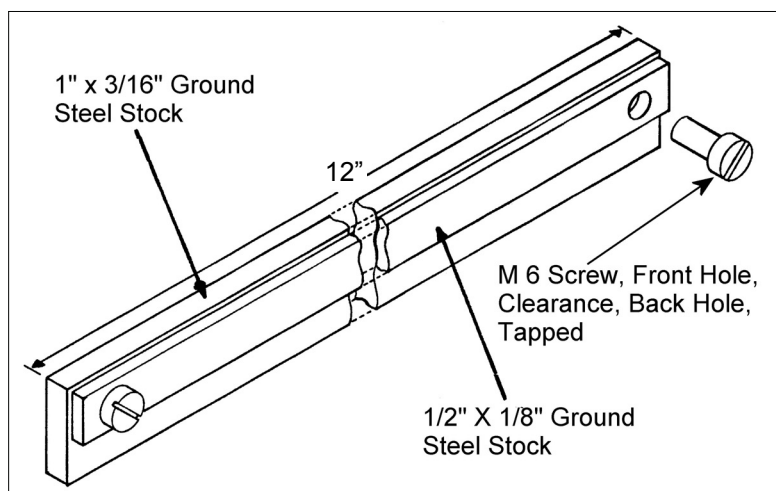

You will find a set of these very useful and here are details of the set that I have made for myself, in fact I have made three sets of different sizes. The dimensions or materials are not critical so make yourself a set to suit the materials you can get hold of. The important thing is that you can clamp the part along its entire length, with the etched fold line just above the front bar. Then clamp the bars in the jaws of your vice, a couple of 1" G clamps are also useful for long folds, and laying a steel rule at the back of the part to help transfer the pressure from your

fingers evenly, pull forward to make the fold. Once the fold is close to 90° you can finish by pressing down on it with a block of wood and moving the block along the fold with a stroking action or by giving gentle taps with a small hammer on the wood block. Occasionally it is necessary to emboss bolt heads onto a part before folding, by lining the face of one of the bars with two or three layers of masking tape, you can still clamp the part without crushing the bolt heads but you won't get such a tight fold, so deepen the fold line with a triangular file.

## Can You Help Me?

If you have enjoyed building this kit and have been satisfied with the quality, I would be most grateful if you could recommend it to your friends and fellow modellers. Although my kits are not perfect, I try to put a lot of time and effort into producing them. If I can get extra sales of a kit through customer's personal recommendation and I find that word of mouth is the best form of advertising. This will help me to put extra time and money into developing the next kit. Hopefully this will give me more satisfied customer to recommend my kits to their friends.

If you are not happy with this kit then please tell me. Hopefully I will then be able to help and sort out any problem.

**Best Regards And Happy Modelling**

**Jim McGeown**